

44MT™

HEAVY DUTY GEAR REDUCTION STARTER
12V/8.5kW



WE START THE WORLD & KEEP IT RUNNING™

44MT™

Every start. Every time.

Trucking
'11 Top 20

Winner of the 2011
**Heavy Duty
Trucking
Best of the Best Award**

With changes due to emission standards and anti-idling regulations, engines are harder to crank and require more starts per day than ever before. Extreme conditions and frequent starts and stops require a starter that is more robust and durable.

The Delco Remy 44MT gear reduction starter addresses all of these issues and more. It delivers with its increased cranking power, durability, and extended life cycle all in a compact, lightweight self-contained design.

FAST. POWERFUL. RELIABLE.

- Delivers high demand torque needed for big bore engines (8.5 kW @ 12 volts)
- The unique, redefined electrical soft start consistently and accurately engages the pinion with the ring gear
- The patented internal magnetic solenoid switch (IMSS) protects from vibration and corrosion caused by environmental factors
- Over crank protection (OCP), a built-in circuit breaker, protects the starter from thermal damage, automatically resetting at a safe operating temperatures

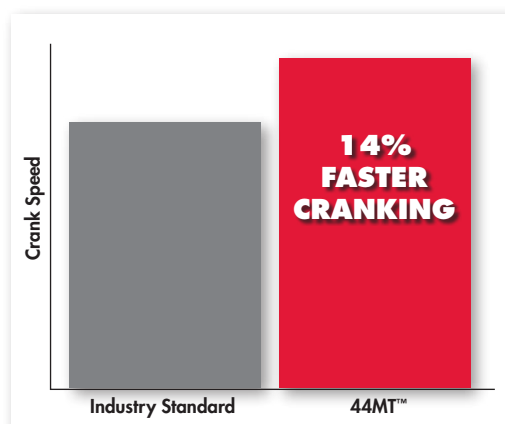

Test Conditions

- Big bore engine
- 0°F (-17.8°C)
- 70% battery state of charge

Results

- Reduced pinion & ring gear wear
- Less overall battery draw



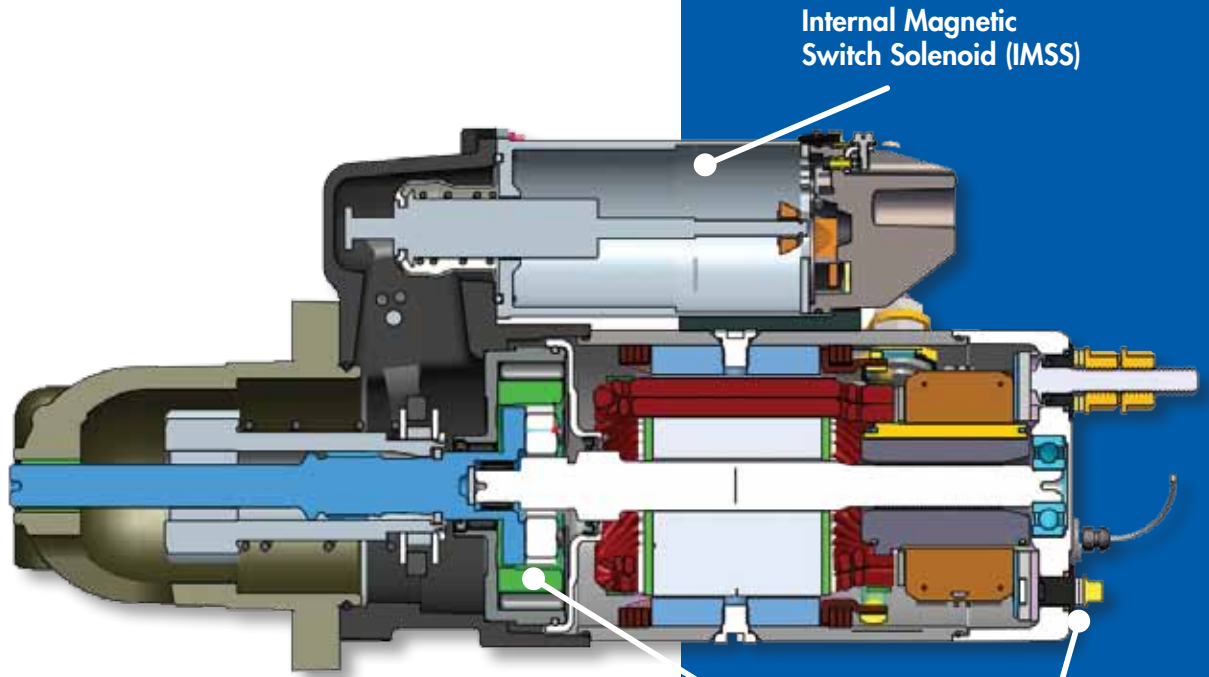

UNMATCHED SERVICE FLEXIBILITY.

- The rotatable nose design provides the ability for part number consolidation, resulting in less inventory
- The new, self-contained, one-wire, overcrank protection design completely eliminates the need for a special wiring harness
- The gear reduction starter design is compact and lightweight for simplified installation

Clutch Over
Planetary
Gear Drive
System (COPG)

Integrated
Over Crank
Protection
(OCP)

SPECIFICATIONS

Engine Size	up to 16 liter
Rotation	Clockwise
Mounting	SAE #1, SAE #3
Pinion Data	SAE: 11 Tooth, 6-8 Pitch SAE: 12 Tooth, 8-10 Pitch SAE: 12 Tooth, Mod 3-metric
Output	8.5kW peak at 12V
Temperature Rating	120° C / 248° F
Weight	17.7 kg / 39.0 lbs
Overall Length	437 mm / 17.2 inches
Diameter	115 mm / 4.53 inches

COMPETITIVE SIZE & POWER COMPARISON

Starter Model	Overall Length (mm)	Diameter (mm)	Weight (kg)	Power Rating (kW)
Delco Remy 44MT™	437	115	17.7	8.5
Delco Remy 39MT™	417	115	14.7	7.3
Denso R5	325	100	10.7	5.0
Leece Neville Titan M125	443	144	18.1	8.0
Mitsubishi 105	403	105	13.0	6.0

WARRANTY
44 month
440,000 miles



Cross Reference

OEM	Engine	Pinion Pitch / Teeth	44MT New Service Part #	39MT OE Part #	39MT Rotatable Flange Part #	Mitsubishi 105	Leece Neville Titan 125
Autocar	Cummins ISC, ISL, ISL-G	8/10 - 12 tooth	8200770	8200218 8200219	8200433	N/A	N/A
	Cummins ISX, ISM	6/8 - 11 tooth	8200750	8200091 19011530	8200308	N/A	N/A
Freightliner Sterling Western Star	MBE 4000	Mod 3 metric 12 tooth	8200771	8200082 8200084 19011514 19011525	8200434	MIB971179, MIB971179FL, FL1179	M125600
	Cummins ISC, ISL	8/10 - 12 tooth	8200770	8200081 8200087 19011517 19011526	8200433	N/A	N/A
	CAT C15 Cummins ISX, ISM, M11 Detroit S60	6/8 - 11 tooth	8200750	8200090 8200091 19011518 19011530 19011521 19011529	8200308	MIB970975, MIB970975FL, FLO975, MIB970777, MIB970777FL, FLO777, FLO579	M125601
	Detroit DD13/15/16	Mod 3 metric 12 tooth	8200771	8200329 8200298	8200434	N/A	M125600
Kenworth Peterbilt	CAT C9, C10, C11 C12, C13, C15, C16 Cummins ISX, ISM, M11	6/8 - 11 tooth	8200750	8200050 8200090 8200104 8200405 19011529	8200308	D61-6002-004, D61-6002-008, PC0979, PC1479, PC1879, M983579	M125601
Mack	Cummins ISL, ISL-G	8/10 - 12 tooth	8200770	8200768	8200433	N/A	N/A
	Mack E7	6/8 - 11 tooth	8200750	8200037 19011500 19011505 19011531	8200308	MK0077	M125601
	Mack MP7	8/10 - 11 tooth	TBA	8200223	N/A	21001797, MK1075	N/A
	Mack MP8	8/10 - 12 tooth	TBA	8200214 8200572		21019460, MK2078, MK2079	M125634
Mack MP10		8200770	8200182	8200433	21045969		
Navistar	Cummins ISX, ISM, M11 CAT C11, C13, C15, C16	6/8 - 11 tooth	8200750	8200050 8200091	8200308	3815734C91 IN1478	M125601
	DT466 DT570 HT570 Maxforce DT, 9, 10	8/10 - 12 tooth	8200770	8200081 8200218 8200219 8200360	8200433	MITIN1378	N/A
	MaxForce 11/13	8/10 - 12 tooth	8200802	8200210 8200606		3667911C91, IN2178	N/A
	MaxForce 15	8/10 - 12 tooth	8200750	N/A	N/A	N/A	N/A
Volvo	Volvo D12	8/10 - 12 tooth	8200770	8200186 8200058 19011515	8200433	W0279	N/A
	Cummins ISX, ISM	6/8 - 11 tooth	8200750	8200091 19011516 19011530	8200308	20851006, W0776, W0977	M125601
	Volvo D11	8/10 - 11 tooth	TBA	8200223	N/A	21001781, W1076	N/A
	Volvo D13	8/10 - 12 tooth	TBA	8200214 8200572		21019456, W2079, W2080	M125634
	Volvo D16		8200770	8200182		8200433	21001825, W1979



Part numbers fast at delcoremy.com

Remy Inc. is a leading global manufacturer of Delco Remy brand heavy duty starters and alternators, light duty starters and alternators, and electric motor technology for EV and hybrid vehicles. We lead with product innovation and performance – you win with trusted, knowledgeable support.



Remy Inc.
600 Corporation Drive
Pendleton, IN 46064 USA
For Technical Assistance call 1-800-372-0222

delcoremy.com

Delco Remy is a registered trademark of General Motors Corporation, licensed to Remy Inc., Pendleton, IN 46064
PRINTED IN USA | C11131 | 1-12