

**38MT & 39MT POSITIVE AND NEGATIVE BRUSHES REPLACEMENT INSTRUCTIONS**

**NOTICE!** Replacing brush assemblies successfully requires proper welding equipment and resistance welding knowledge to produce quality dependable welds that are necessary in replacing brush assemblies.

**NOTE:** It is beneficial and possibly necessary to obtain one of these hardware packages for reassembly of the starter. It is preferable to use new, undamaged parts.

**WARNING!!!** ALWAYS USE PROPER EYE PROTECTION WHEN PERFORMING ANY MECHANICAL REPAIRS TO A VEHICLE – INCLUDING, BUT NOT LIMITED TO, ANY INSTALLATION AND OR REPAIRS TO THE DELCO<sup>®</sup> STARTING MOTORS. FAILURE TO USE PROPER EYE PROTECTION CAN LEAD TO SERIOUS AND PERMANENT EYE DAMAGE.

**FOLLOW ENGINE AND/OR VEHICLE MANUFACTURER'S INSTRUCTIONS CAREFULLY WHEN REMOVING AND INSTALLING THE STARTER.**

**Limitation of Liability:** In no event, regardless of cause, will Remy International be liable for any loss, injury or damage to persons or property, including any indirect, special, incidental, punitive or consequential damages of any kind, whether arising under breach of contract, tort (including negligence), strict liability or otherwise resulting from the use of this product.

Remy International will have no liability for any claim based upon or arising out of (1) the operation or use of this product in a manner for which it was neither designated or contemplated, or (2) product failures resulting from poor execution of the instructions described herein.

**REMOVAL PROCEDURES**

**DANGER!!!** ALWAYS DISCONNECT BATTERY GROUND BEFORE REMOVING OR REPLACING CABLES AT THE STARTER. FAILURE TO DISCONNECT THE BATTERY GROUND CABLE CAN LEAD TO SERIOUS INJURY.

**EQUIPMENT & SKILLS REQUIRED:** The preferable process for achieving quality dependable welds of the brush leads to the field coils or brush plate is Resistance Brazing. Resistance brazing requires a resistance welding machine capable of supplying at least 15,000 amperes through a set of Molybdenum Tipped copper electrodes with about 500 pounds of force. Sil-Fos and Fos-Flo filler metals are for use (inserted between parts to be welded) with copper and copper alloy base metals. Remy International uses the AWS designation Sil-Fos BCuP-5 to produce high quality, dependable weld joints with the brush leads. The welding set up should be checked with some appropriate test such as material transfer prior to welding the brush and motor terminal leads to the respective components.

These welding functions should only be performed by experienced persons, using proper equipment. If these repairs are beyond your technical capabilities, they should be handled by a welding specialist or welding facility.

**REFERENCE:** There are exploded parts views of 38MT & 39MT starters for easy reference on page 2. More detailed exploded views can be found on the [www.delcoremy.com](http://www.delcoremy.com) website under products and service parts.

**DISASSEMBLY PROCEDURES**

1. Separate the brush holder assembly from the frame & field assembly.
2. Remove the field coils from the frame and all parts from the brush holder assembly.
3. Separate the negative (-) brush leads from the brush plate and dispose of them.
4. Separate the positive (+) brush leads and motor terminal lead from the field coils and dispose of them.
5. Clean the welded area surfaces thoroughly by grinding with a small "Dresser tool" or similar device. All evidence of the copper strands must be removed prior to welding the replacement parts.
6. Bend the field coil straps just enough for welding, being careful not to damage the insulation.

**REASSEMBLY PROCEDURES**

1. Weld the motor lead assembly and the brush assemblies to the field coils and bend the straps back as they were before.
2. Apply Three Bond 1401B or equivalent anti-loosening agent to each pole shoe screw.
3. Reassemble the field coils, insulator, pole shoes and torque the pole shoe screws to **30.6 - 51.0 Nm (22 - 51lb ft)**.  
Check to insure there is clearance for the armature assembly to turn freely without rubbing.
4. Weld the brush assemblies to the brush holder plate and reassemble the parts as removed.
5. Reassemble the brush holder and frame and field assemblies.

**NOTICE** - Only licensed Remy International, Inc. product and component parts should be used, and the use of other parts or modifications not approved by Remy International, Inc. will void all applicable warranties. The failure to carefully follow these Installation Instructions, set forth above, will void all applicable warranties. DELCO REMY is a registered trademark of General Motors Corporation, licensed to Remy International, Inc. Pendleton, IN 46064.

THESE EXPLODED PARTS VIEWS OF 38MT & 39MT STARTERS ARE AVAILABLE ON [www.delcoremy.com](http://www.delcoremy.com) WEBSITE UNDER PRODUCTS AND SERVICE PARTS

Limitation of Liability: In no event, regardless of cause, will Remy International be liable for any loss, injury or damage to persons or property, including any indirect, special, incidental, punitive or consequential damages of any kind, whether arising under breach of contract, tort (including negligence), strict liability or otherwise resulting from the use of this product.

Remy International will have no liability for any claim based upon or arising out of (1) the operation or use of this product in a manner for which it was neither designated or contemplated, or (2) product failures resulting from poor execution of the instructions described herein.

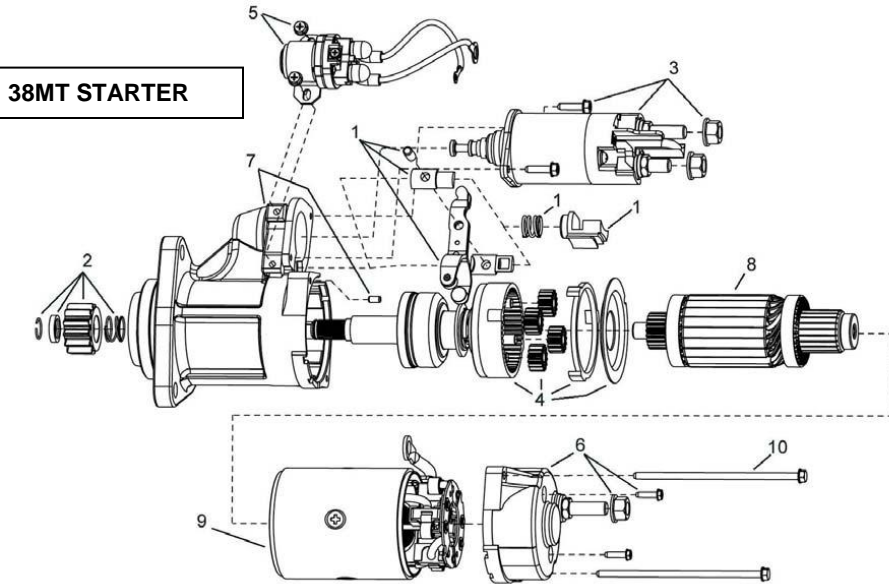

**38MT SERVICE PARTS PACKAGES**

1. LEVER
2. PINION
3. SOLENOID ASSEMBLY
4. DRIVE SHAFT ASSEMBLY (WITHOUT PINION)
5. INTEGRAL MAGNETIC SWITCH (IMS)
6. CE HOUSING
7. DRIVE HOUSING (NOSE)
8. ARMATURE ASSEMBLY
9. BRUSH & FRAME ASM.
10. THRU BOLTS

HARDWARE PACKAGE MAY BE NECESSARY

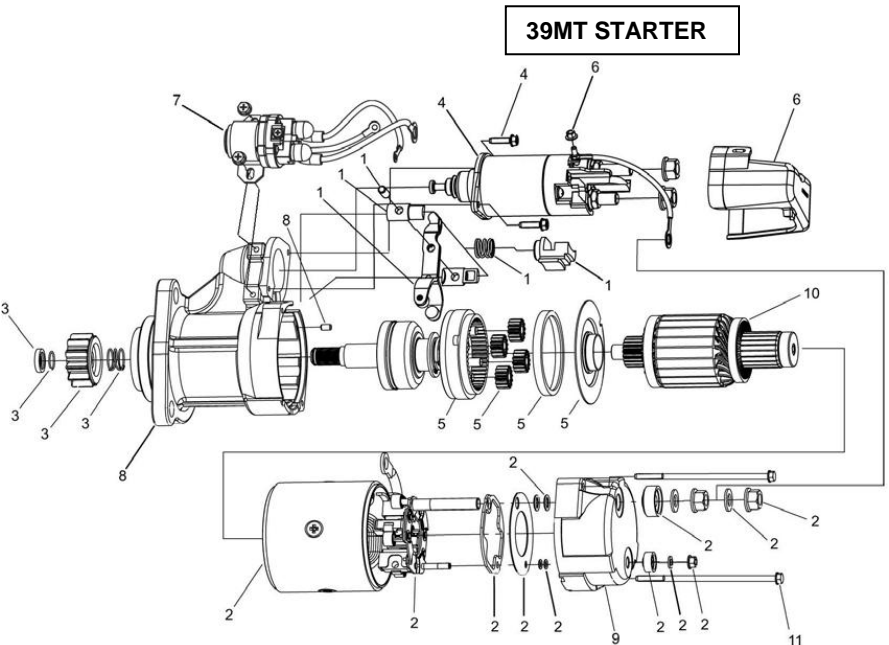

**39MT SERVICE PARTS PACKAGES**

1. LEVER
2. BRUSH & FRAME
3. PINION
4. SOLENOID ASSEMBLY
5. DRIVE SHAFT ASSEMBLY
6. JUMP START PROTECTION (JSP)
7. INTEGRAL MAGNETIC SWITCH (IMS)
8. DRIVE HOUSING (NOSE)
9. CE HOUSING
10. ARMATURE ASSEMBLY
11. THRU BOLTS

HARDWARE PACKAGE MAY BE NECESSARY

Technical support: USA 800 854 0076, Mexico 01 800 000 7378, Brazil 0800 703 3526, South America 55 11 2106 6510 or visit [delcoremy.com](http://delcoremy.com)

**NOTICE** - Only licensed Remy International, Inc. product and component parts should be used, and the use of other parts or modifications not approved by Remy International, Inc. will void all applicable warranties. The failure to carefully follow these Installation Instructions, set forth above, will void all applicable warranties. DELCO REMY is a registered trademark of General Motors Corporation, licensed to Remy International, Inc. Pendleton, IN 46064.