

INSTALLING BEARINGS IN 50DN OIL-COOLED GENERATORS

WARNING!!! ALWAYS USE PROPER EYE PROTECTION WHEN PERFORMING ANY MECHANICAL REPAIRS TO A VEHICLE – INCLUDING, BUT NOT LIMITED TO, ANY INSTALLATION AND OR REPAIRS TO THE DELCO REMY GENERATORS. FAILURE TO USE PROPER EYE PROTECTION CAN LEAD TO SERIOUS AND PERMANENT EYE DAMAGE.

Only perform the mechanical functions that you are properly qualified to perform. Mechanical repairs that are beyond your technical capabilities should be handled by a professional installation specialist.

1. Install single row ball bearing into drive end frame with seal toward rotor. Seat bearing into housing bore by pressing on **outer race only**. Assemble retainer plate and stake screws using center punch on edge of screw head.
2. Insert spacer; use hollow cylinder, 2.75"-2.62" Outside Diameter, 1.25"-1.50" Inside Diameter, and 2" long, to press roller bearing outer race about halfway into housing. Start roller bearing inner race by moving and rotating part until it enters and seats against the spacer. Finish pressing outer race with cylinders until it seats flush with inner race.
NOTICE: Do not exert excessive force on roller bearing inner race because this will cause the ball bearing races to become brinelled, thus reducing the bearing life.
DO NOT mix roller bearing races because they are **matched** for proper roller clearance.
3. Support inside of rotor with bar stock 2" diameter x 5" long on arbor press. With rotor shaft upright, press on inner race with cylinder used in Step 2 to press bearing and housing assembly onto shaft.

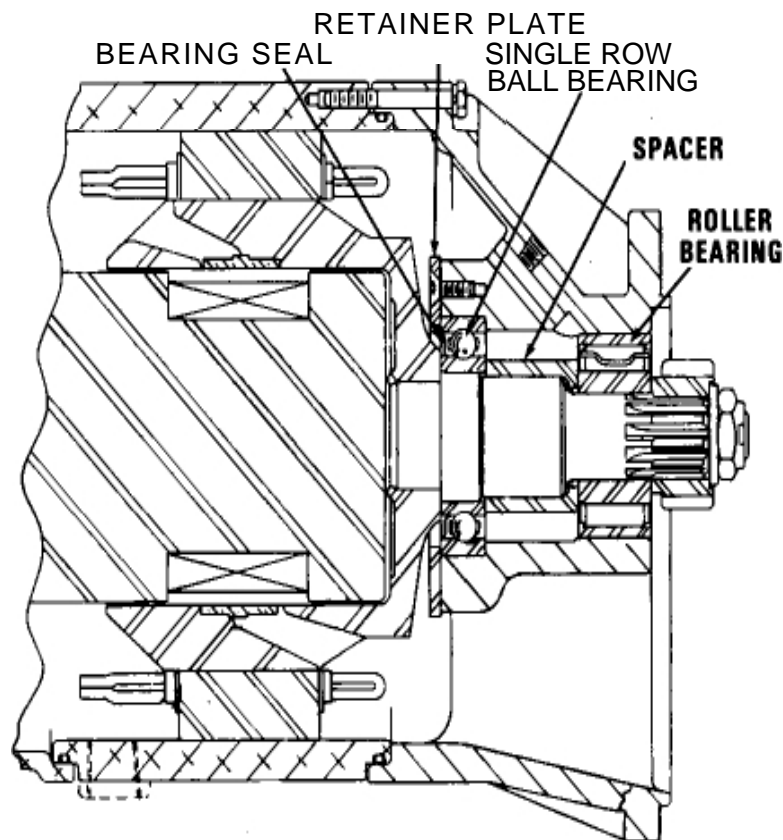

WARNING - Be aware that only licensed Remy Inc. product and component parts should be used and the use of other parts or modifications not approved by Remy Inc. will void any warranty concerning, but not limited to, product performance or reliability. The failure to carefully follow Installation Package guidelines set forth above will likewise void any and all warranty, **including the implied warranties of merchantability and fitness for a particular purpose.** Delco Remy® is a registered trademark of General Motors Corporation, licensed to Remy Inc., Anderson, IN 46013.