

## INSTALLING 28MT & 29MT GEAR REDUCTION HEAVY DUTY STARTING MOTORS

**WARNING!!!** ALWAYS USE PROPER EYE PROTECTION WHEN PERFORMING ANY MECHANICAL REPAIRS TO A VEHICLE – INCLUDING, BUT NOT LIMITED TO, ANY INSTALLATION AND OR REPAIRS TO THE DELCO REMY STARTING MOTORS. FAILURE TO USE PROPER EYE PROTECTION CAN LEAD TO SERIOUS AND PERMANENT EYE DAMAGE.

Only perform the mechanical functions that you are properly qualified to perform. A professional installation specialist should handle mechanical repairs that are beyond your technical capabilities.

**DANGER!!!** ALWAYS DISCONNECT BATTERY GROUND BEFORE REMOVING OR REPLACING CABLES AT THE STARTER. FAILURE TO DISCONNECT THE BATTERY GROUND CABLE CAN LEAD TO SERIOUS INJURY.

**NOTICE!** Some applications use a starter with a magnetic switch (relay) directly attached. Replacing it with a starter without an attached magnetic switch (relay) is not recommended, because it requires installing a separately mounted magnetic switch (relay) and potentially upgrading the solenoid control circuit wiring. The switch and wiring must meet or exceed a current rating of 300 amperes for 12V starters and 200 amperes for 24V starters. **When replacing a 24V starter on all vehicles prior to 1990, the control circuit must be checked for conformance to the 200 ampere requirement.**

**NOTE** STARTER MAY BE VERY DIFFERENT IN SIZE AND APPEARANCE THAN THE ONE BEING REPLACED. A NOSE LESS TYPE DRIVE HOUSING STARTER CAN REPLACE A STARTER WITH A NOSE TYPE DRIVE HOUSING.

**FOLLOW ENGINE AND/OR VEHICLE MANUFACTURER'S INSTRUCTIONS FOR STARTING MOTOR REMOVAL AND INSTALLATION.**

### REPLACEMENT PROCEDURES (See figures 1 & 2, page 2)

1. Disconnect ground (-) cable at the battery and note position of leads connected to the starter.
  2. Remove, identify and tag all leads so they can be connected to the same terminals on the new starter.
  3. Remove starter mounting bolts and retain for reinstallation.
  4. Note if any shims and/or spacer washers were used between the starter and flywheel housings. They must be reinstalled in the exact same location.
  5. Clean or wire brush all terminals so that bare metal is present for good connections.
  6. Examine the ring gear for damage and replace, if necessary, to avoid a potential premature failure and risk rejection of a warranty claim.
- 
1. Replace any shims or spacer washers, as removed, and tighten mounting bolts according to engine or vehicle manufacturer's specifications. Do not use any lock, star or soft washers with the starter mounting bolts.
  2. Connect lead to solenoid switch terminal as removed from the old starter solenoid and torque to 2.0-2.25 Nm (18-20 lb in). If replacement starter has an attached magnetic switch (relay), connect this lead to the switch terminal of the magnetic switch (relay) and torque to 1.9-2.5 Nm (17-22 lb in).
  3. Connect cables to solenoid battery (+) terminal as removed from the old starter and torque to 14.7-17.7 Nm (11-13 lb ft).
  4. Connect ground (-) cable to ground terminal on starters that have one, as removed from the old starter and torque to 14.7-17.7 Nm (11-13 lb ft).

**All electrical connections must be clean and tight. Good connections with proper cable sizes and suitable batteries are essential to obtain the best performance from this starter.**

### INTEGRATED MAGNETIC SWITCH (IMS) REPOSITIONING (Figure 2, page 2)

- ◆ Remove the two IMS mounting screws and loosen fasteners that attach the IMS leads to the solenoid, if necessary.
- ◆ Reposition IMS by using a different set of drive housing switch mounting bracket holes to obtain clearance.
- ◆ **Reinstall mounting screws and torque all fasteners according to values labeled in figure 2, page 2.**

### BATTERY COLD CRANKING AMPERES (CCA)

Excessive available CCA can damage starters. **CCA** rating is the current a battery can supply at "0" degree F (-18C) [See TMC RP 109A]. **Following are Maximum Battery CCA Recommendations for Delco Remy Starters by Series:**

<b>28MT</b>	12V	1100 CCA	<b>29MT</b>	12V	2500 CCA
	24V	900 CCA		24V	1250 CCA

**WARNING -** Be aware that only licensed Remy Inc. product and component parts should be used and the use of other parts or modifications not approved by Remy Inc. will void any warranty concerning, but not limited to, product performance or reliability. The failure to carefully follow Installation Package guidelines set forth above will likewise void any and all warranty, **including the implied warranties of merchantability and fitness for a particular purpose.** Delco Remy® is a registered trademark of General Motors Corporation, licensed to Remy Inc., Anderson, IN 46013.

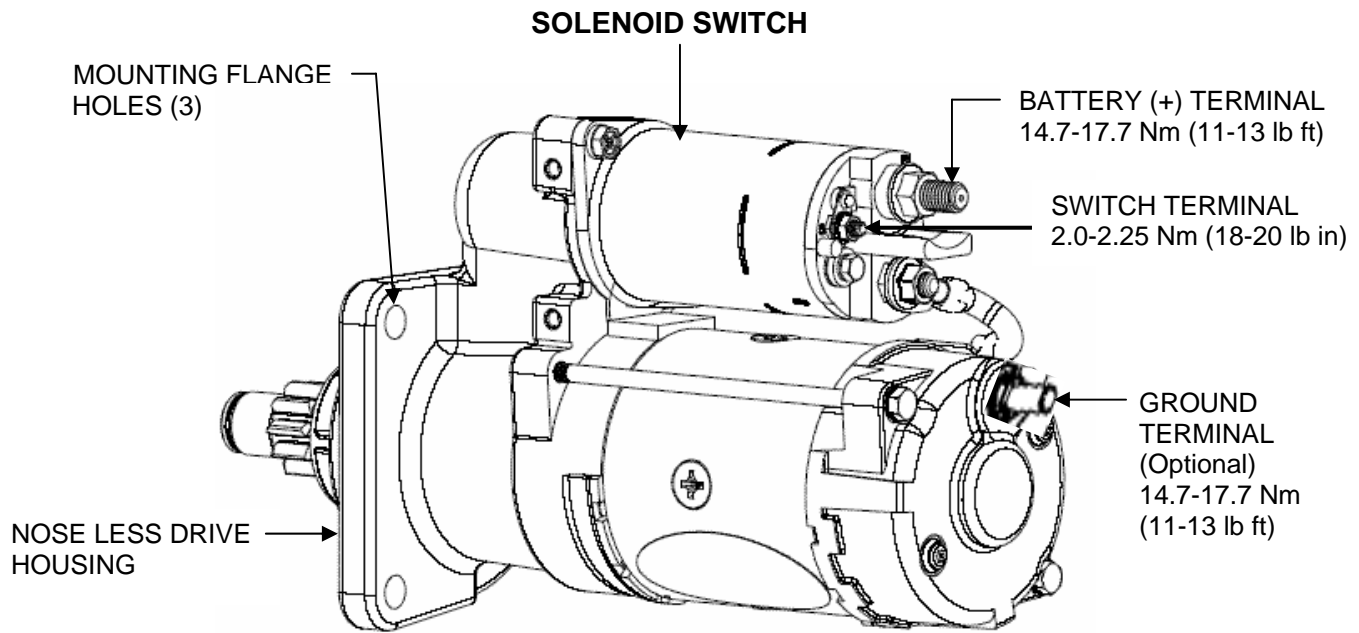

**FIGURE 1**

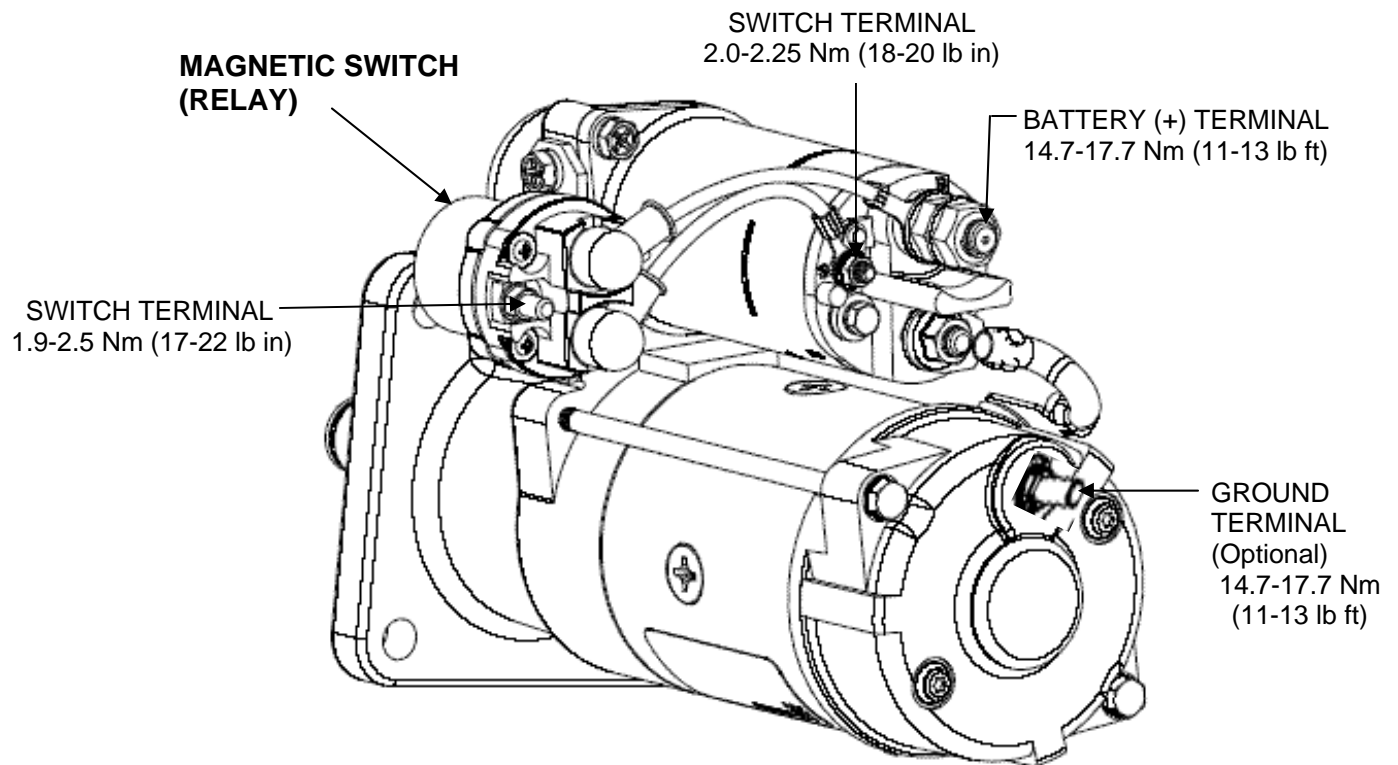

**FIGURE 2 – MAGNETIC SWITCH (RELAY) ATTACHED**