

INSTALLING DELCO REMY HEAVY DUTY STARTING MOTORS (37MT, 40MT, 41MT, 42MT & 50MT)

WARNING!!! ALWAYS USE PROPER EYE PROTECTION WHEN PERFORMING ANY MECHANICAL REPAIRS TO A VEHICLE – INCLUDING, BUT NOT LIMITED TO, ANY INSTALLATION AND OR REPAIRS TO THE DELCO REMY STARTING MOTORS. FAILURE TO USE PROPER EYE PROTECTION CAN LEAD TO SERIOUS AND PERMANENT EYE DAMAGE.

Only perform the mechanical functions that you are properly qualified to perform. A professional installation specialist should handle mechanical repairs that are beyond your technical capabilities.

DANGER!!! ALWAYS DISCONNECT BATTERY GROUND BEFORE REMOVING OR REPLACING CABLES AT THE STARTER. FAILURE TO DISCONNECT THE BATTERY GROUND CABLE CAN LEAD TO SERIOUS INJURY.

NOTICE! FOLLOW ENGINE AND/OR VEHICLE MANUFACTURER'S INSTRUCTIONS CAREFULLY WHEN REMOVING AND INSTALLING THE STARTERS.

DRIVE HOUSINGS WITH ROTATABL POSITIONING (Figure 1, page 2)

- ◆ These starter types are provided with 12 or 24 positions for locating the solenoid, so that many models may be serviced with only a few. This flexibility permits removing any interference of the solenoid upon installation.
- ◆ Repositioning can be accomplished by removing the six (6) TORX nose housing bolts, rotating the switch housing and reassembly. Torque bolts to **17.6-23.0 Nm (13-17 lb ft)**. **NOTICE! Do not reuse the bolts on wet clutch applications.**
- ◆ Some **42MT** and **50MT** Starters have wax coated nose housing bolts and other sealing features to prevent oil from leaking. The clutch area is heavily splashed with engine oil on these applications. The wax coating sealing effectiveness is reduced during installation and removal, increasing potential for leakage. Use of new bolts is highly recommended.
42MT - Replace with six (6) new Delco Remy 10499643 bolts.
50MT - Replace with five (5) new Delco Remy 10475536 bolts and one (1) 10499643 bolt.
- ◆ After rotation of starters using 5/8" mounting bolts, the lever housing boss may interfere with the wrench used for tightening. If this is a problem, use a special 12-Point Head Cap Screw (Grade 5).
- ◆ Solenoid must be mounted in an upward position for housing to drain. A few models have solenoids and drains inverted.
- ◆ A heat resistant shield must be used if the solenoid is within two inches of the exhaust manifold.

INTEGRATED MAGNETIC SWITCH (IMS) REPOSITIONING (Figure 3, page 2)

- ◆ Remove the two IMS mounting screws and loosen fasteners that attach the IMS leads to the solenoid, if necessary.
- ◆ Reposition IMS by using a different set of solenoid mounting screws and/or set of bracket holes to obtain clearance.
- ◆ **Reinstall mounting screws and torque all fasteners according to values labeled in figure 3, page 2.**

MOUNTING FLANGE HOLES AND BOLTS (Figures 1, 2 & 3, page 2)

- ◆ This starter may have either 13.4-13.7 mm (1/2") or 16.6-16.9 mm (5/8") diameter mounting flange holes. Both starters can also be mounted with 1/2" or metric equivalent mounting bolts. Hex Head Cap Screws (Grade 5) should be used.
NOTICE! If Hex Head Size is too small, use a hardened washer or special 12-Point Head Cap Screw (Grade 5).
- ◆ Do not use any lock washers, star washers or soft washers with the starter mounting bolts.
- ◆ **If any shims and/or spacer washers were used with the old starter, between the starter and flywheel housings, they must be reinstalled in exactly the same location with this starter.**

GROUNDING INSULATED STARTING MOTORS (Figures 2 & 3, page 2)

This may be an insulated starter replacing a grounded type starter. Insulated starters have a flexible cable connecting the solenoid ground terminal to terminal on the commutator end of the starter (labeled Insulated/Ground). An insulated starter must have a cable connecting this terminal to the battery ground (-) connection for the starter to function. This grounding cable between the starter and battery should be a copper cable the same size as the positive (+) battery cable being used.

ELECTRICAL CONNECTIONS (Figures 2 & 3, page 2)

- ◆ Identify and tag all leads when removing old starter so they can be properly connected on the new starter. Be sure to connect the cables to correct solenoid terminals, because the terminals may be reversed.
- ◆ Clean or wire brush all terminals so that bare metal is exposed for good electrical connections.
- ◆ The connector for starters with optional Over Crank Protection (**OCP**) is the same for all series of starters.
- ◆ **Tighten all fasteners according to torque values labeled on the illustrations.**

RING GEAR

- ◆ If the ring gear is damaged, it must be replaced to avoid a potential early failure and risk rejection of a warranty claim.

BATTERY COLD CRANKING AMPERES (CCA)

Excessive available CCA can damage starters. **CCA** rating is the current a battery can supply at '0' degree F (-18C) [See **TMC RP 109A**]. **Following are Maximum Battery CCA Recommendations for Delco Remy Starters by Series:**

37MT 12V 1875 CCA	40MT 12V 2500 CCA	41MT 12V 1875 CCA	42MT 12V 2500 CCA	50MT 12V 3600 CCA
24V 900 CCA	24V 1250 CCA	24V 900 CCA	24V 1250 CCA	24V 1800 CCA

ELECTRICAL INSTALLATION INSTRUCTIONS (See figures 2 & 3, page 2)

REVIEW DESCRIPTIONS IN THE TABLE BELOW TO DETERMINE THE FEATURES OF THIS STARTER VS THE ONE BEING REPLACED. THE SET OF INSTRUCTIONS TO FOLLOW MUST BE SELECTED BASED ON FEATURES OF BOTH STARTERS. **NOTE** THIS STARTER MAY ALSO BE VERY DIFFERENT IN SIZE AND APPEARANCE THAN THE ONE BEING REPLACED.

	New Starter	Old Starter	Install
A	Magnetic Switch (Relay) not attached to starter	Magnetic Switch (Relay) not attached	Yes
B	Magnetic Switch (Relay) attached to starter	Magnetic Switch (Relay) attached	Yes
C	Magnetic Switch (Relay) attached to starter	Magnetic Switch (Relay) not attached	Yes

A Starter and starter being replaced do not have an attached magnetic switch (relay).

1. Connect lead to solenoid switch terminal as removed from old starter solenoid.
2. Connect positive (+) cable to solenoid battery (+) terminal as removed from old starter.
3. Connect ground (-) cable to insulated/ground terminal on starters that have one, as removed from old starter.

B Starter and starter being replaced both have an attached magnetic switch (relay).

1. Connect lead to switch terminal of magnetic switch (relay) as removed from old starter.
2. Connect positive (+) cable to solenoid battery (+) terminal as removed from old starter.
3. Connect ground (-) cable to insulated/ground terminal on starters that have one, as removed from old starter.

C Starter with attached magnetic switch (relay) replacing starter without an attached magnetic switch (relay).

1. If this starter has a lead and connector assembly attached to the switch terminal of the magnetic switch (relay), remove it and dispose. Go to step 2.
2. Connect lead removed from the old solenoid switch terminal to the switch terminal of the magnetic switch (relay) on the new starter. **Note!** The separately mounted magnetic switch (relay) will remain in the circuit and continue to function.
3. Connect positive (+) cable to solenoid battery (+) terminal as removed from old starter. Connect ground (-) cable to insulated/ground terminal on starters that have one, as removed from old starter. Delco Remy strongly recommends the use of a ground cable.

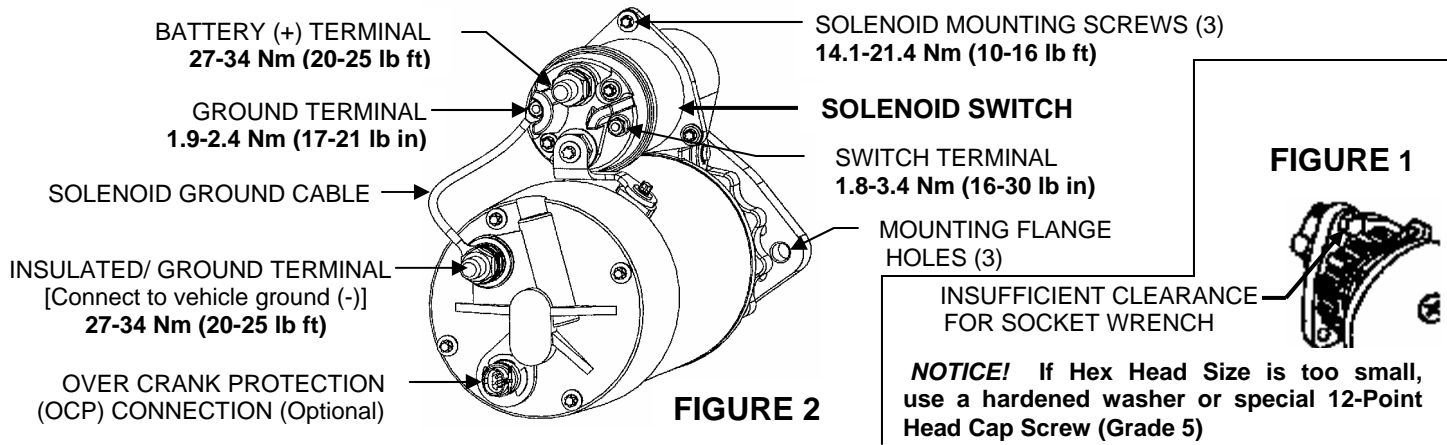

FIGURE 2

FIGURE 1

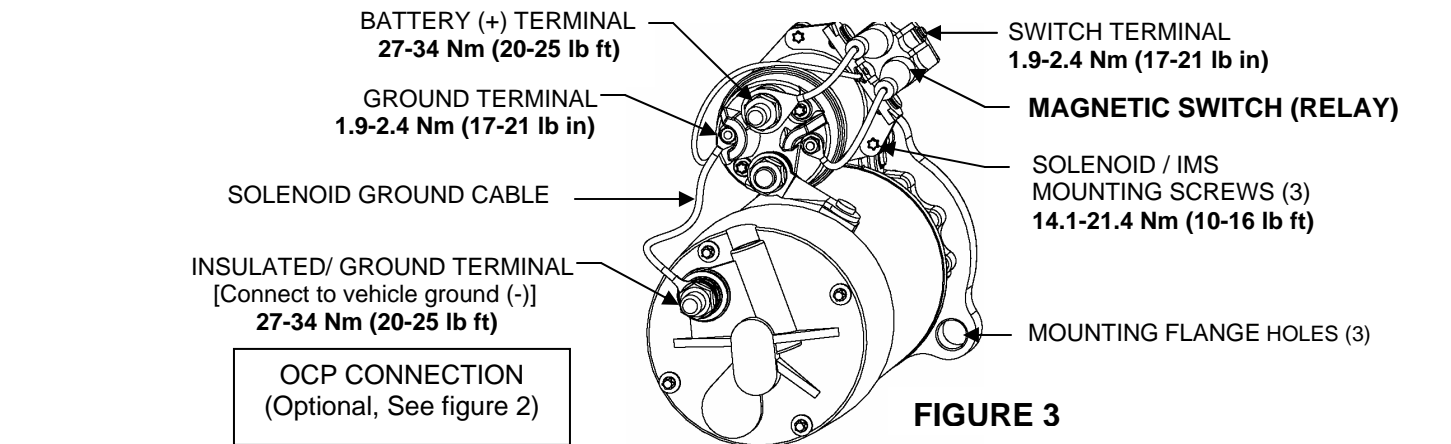

FIGURE 3