



28SI™ ALTERNATOR INSTALLATION INSTRUCTIONS

28SI™ FEATURES

HIGH OUTPUT: 100 (24V) 160 - 180 - 200 (12V) Ampere Ratings

REMOTE SENSE™ TECHNOLOGY

THREE MOUNTING OPTIONS: Pad, Delco Remy® Standard Hinge 198mm (7.8 inch) & Long Hinge 216mm (8.5 inch)

WARNING!!! ALWAYS USE PROPER EYE PROTECTION WHEN PERFORMING ANY MECHANICAL REPAIRS TO A VEHICLE - INCLUDING, BUT NOT LIMITED TO, ANY INSTALLATION AND OR REPAIRS TO THE DELCO REMY® ALTERNATORS. FAILURE TO USE PROPER EYE PROTECTION CAN LEAD TO SERIOUS AND PERMANENT EYE DAMAGE.

Only perform the mechanical functions that you are properly qualified to perform. Mechanical repairs that are beyond your technical capabilities should be handled by a professional installation specialist.

DANGER!!! To avoid injury or damage, always disconnect the negative cable at the battery before removing or replacing the alternator. The alternator output terminal is always live ("hot"). If the battery is not disconnected, a tool accidentally touching this terminal and ground can quickly get hot enough to burn skin or damage tools and surrounding parts.

FOLLOW ENGINE OR VEHICLE MANUFACTURER'S INSTRUCTIONS FOR REMOVING THE OLD ALTERNATOR FROM THE ENGINE AND INSTALLING THE NEW ALTERNATOR.

NOTICE! This is an extremely high output Alternator. Always ensure your application is equipped with the appropriate size and gauge of cable. CHARGING LINE CABLE VOLTAGE DROP SHOULD NOT EXCEED 0.5 VOLTS (12V system), 1.0 Volts (24V system) (ALTERNATOR OUTPUT [B+] TERMINAL TO BATTERY POSITIVE TERMINAL AT FULL OUTPUT). FOR OBTAINING ADDITIONAL WIRING INSTALLATION INFORMATION, SEE HEAVY DUTY APPLICATION MANUALS OR CONTACT A REMY INC. REPRESENTATIVE.

REMOVAL & INSTALLATION INSTRUCTIONS

- ◆ Disconnect the negative (-) cable at the batteries.
- ◆ Identify and tag all leads when removing the old alternator and install them on the same terminals of the new alternator.
- ◆ Insure all leads are reconnected or contained where they cannot ground.
- ◆ **Torque all fasteners to values labeled in Figure 1 below.**
- ◆ This alternator may have more terminals than the one being replaced had or used. It will charge properly with only the battery and ground leads connected. Use of the other terminals is optional based on need. See "TERMINAL DESCRIPTIONS", Pages 2 and 3.

FIGURE 1 - 28SI™ Alternator Torque Values

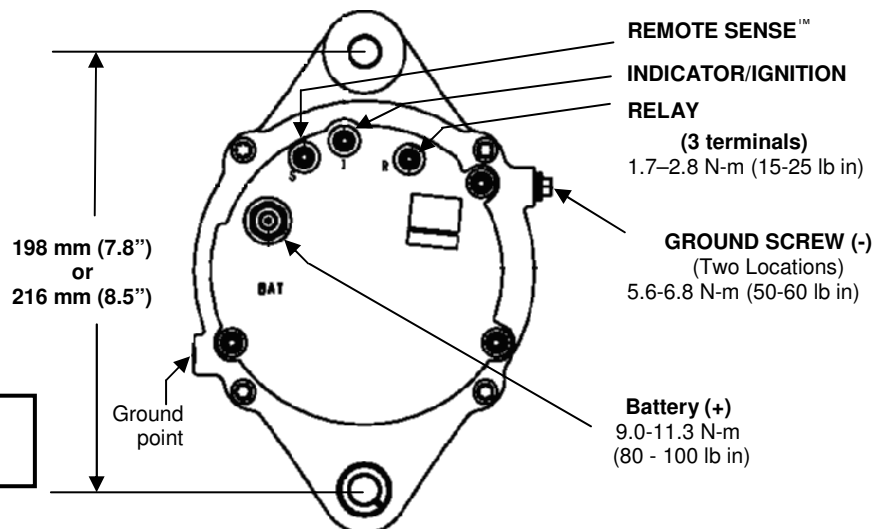

NOTICE! DO NOT INSTALL AN EXTERNAL FAN ON A 28SI ALTERNATOR

AVAILABLE IN DELCO REMY® STANDARD HINGE & LONG HINGE MOUNTING SIZES

USE PULLEY FROM OLD ALTERNATOR (SEE PULLEY INSTRUCTIONS BELOW)

PULLEY INSTRUCTIONS: Use pulley from old alternator if this alternator does not have a pulley or pulley supplied is different from the one on alternator being replaced. **NOTICE!** When changing the pulley, keep the alternator shaft in the horizontal position and do not apply any pressure to end of the shaft. Internal damage may occur if the shaft is pushed back and turned. If there were spacers when the fan and pulley were removed, make sure all spacers are replaced when installing the pulley on this alternator. Hold the shaft by placing a hex wrench in the hexagonal hole in the shaft while removing or installing the pulley. **Tighten the pulley nut to 95-108 N-m (70-80 lb ft).**

NOTICE - Only licensed Remy Inc. product and component parts should be used, and the use of other parts or modifications not approved by Remy Inc. will void all applicable warranties. The failure to carefully follow these Installation Instructions, set forth above, will void all applicable warranties. Delco Remy® is a registered trademark of General Motors Corporation, licensed to Remy Inc., Pendleton, IN 46064.

BELT TENSIONING INSTRUCTIONS: Improper belt tension can cause premature alternator failure. If the belt must be tightened manually, place a wood block between the alternator and pry bar, as illustrated at right. Pry as close to the center of the unit as possible. Use a torque wrench to tighten mounting bolts to the proper torque as specified in vehicle or engine manufacturer's specifications for belt tension and mounting bolts torque. **DO NOT OVER TIGHTEN BELT!**

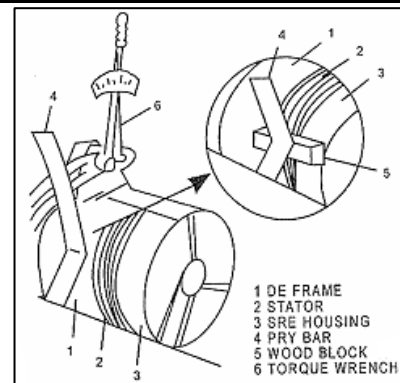

**FIGURE 2 –
TYPICAL WIRING DIAGRAM – 3 Studs**

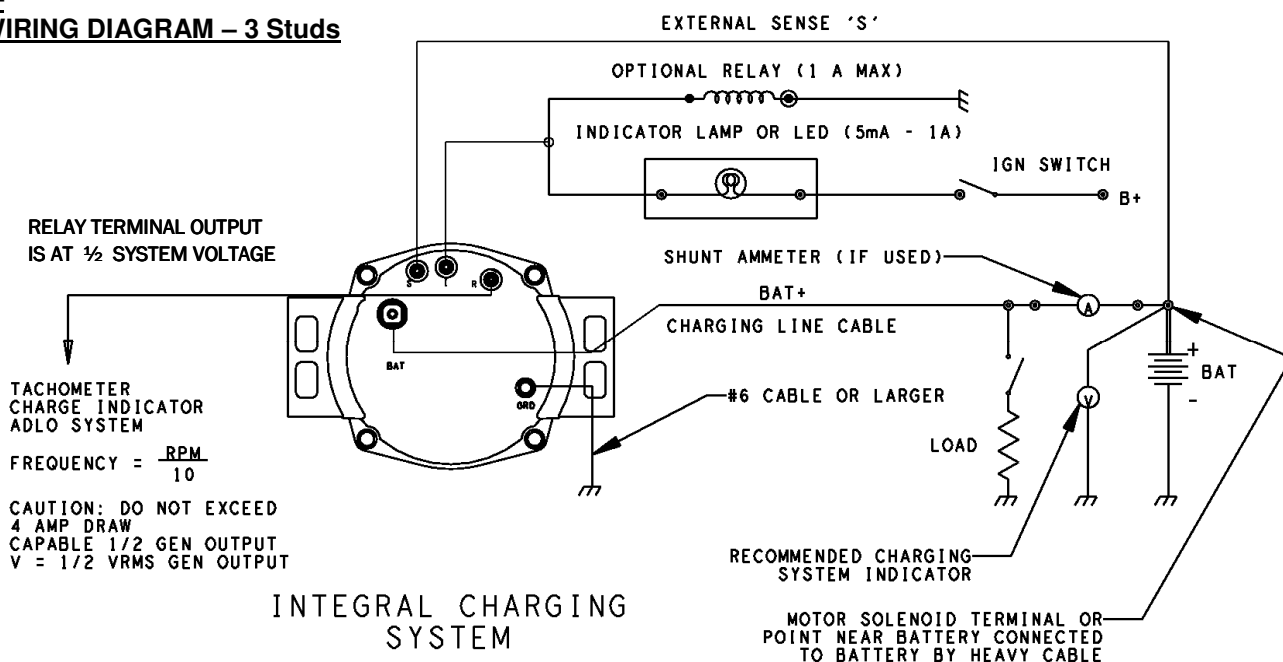

TERMINAL DESCRIPTIONS (Alternator will function without connecting the S, I or R terminals):

“B+” Terminal - Output terminal connects to the positive (+) battery terminal.

“S” Remote Sense™ Terminal – Connect to system voltage at the battery or a common distribution point.

“R” Terminal – Relay / Phase terminal carries half system voltage and may be used for certain types of control relays, charge indicators, tachometers or similar devices. The current draw should not exceed four (4) amperes. Frequency = Alternator RPM/10. **Notice!** The “R” Terminal is not the Remote Sense™ terminal – do not connect to B+!

“I” Terminal - The Indicator lamp/ignition terminal can serve as a current source, sink or both, depending on how it is connected. The diagram above shows one configuration. Current capability is 1.0 Amp in either direction.

Ground Screw – Ground lead ensures alternator is grounded and is strongly recommended for optimum performance.

- ◆ If installing this alternator with Remote Sense™ terminal in a vehicle that does not have a sense line, connect a fused (5 Amp) insulated wire from the Alternator Voltage Sense terminal to the positive (+) battery terminal or the common distribution point at the starter solenoid battery (+) terminal. Connection of this terminal is best for optimum performance; however, the alternator will function without Remote Sense™ connected.

Use a #16 gauge red insulated wire, preferably with a 1/4" ID Convuluted Polyethylene Conduit. Also install a standard inline fuse holder with a protective cap. Use a low voltage automotive standard blade style fuse, 5 Amp.

- ◆ Only connect the Remote Sense™ terminal line to the Remote Sense™ terminal. **The “R” and “I” Terminals are not the Remote Sense™ Terminal!**

NOTICE - Only licensed Remy Inc. product and component parts should be used, and the use of other parts or modifications not approved by Remy Inc. will void all applicable warranties. The failure to carefully follow these Installation Instructions, set forth above, will void all applicable warranties. Delco Remy® is a registered trademark of General Motors Corporation, licensed to Remy Inc., Pendleton, IN 46064.

**FIGURE 3 –
TYPICAL WIRING DIAGRAM – 4 Pin**

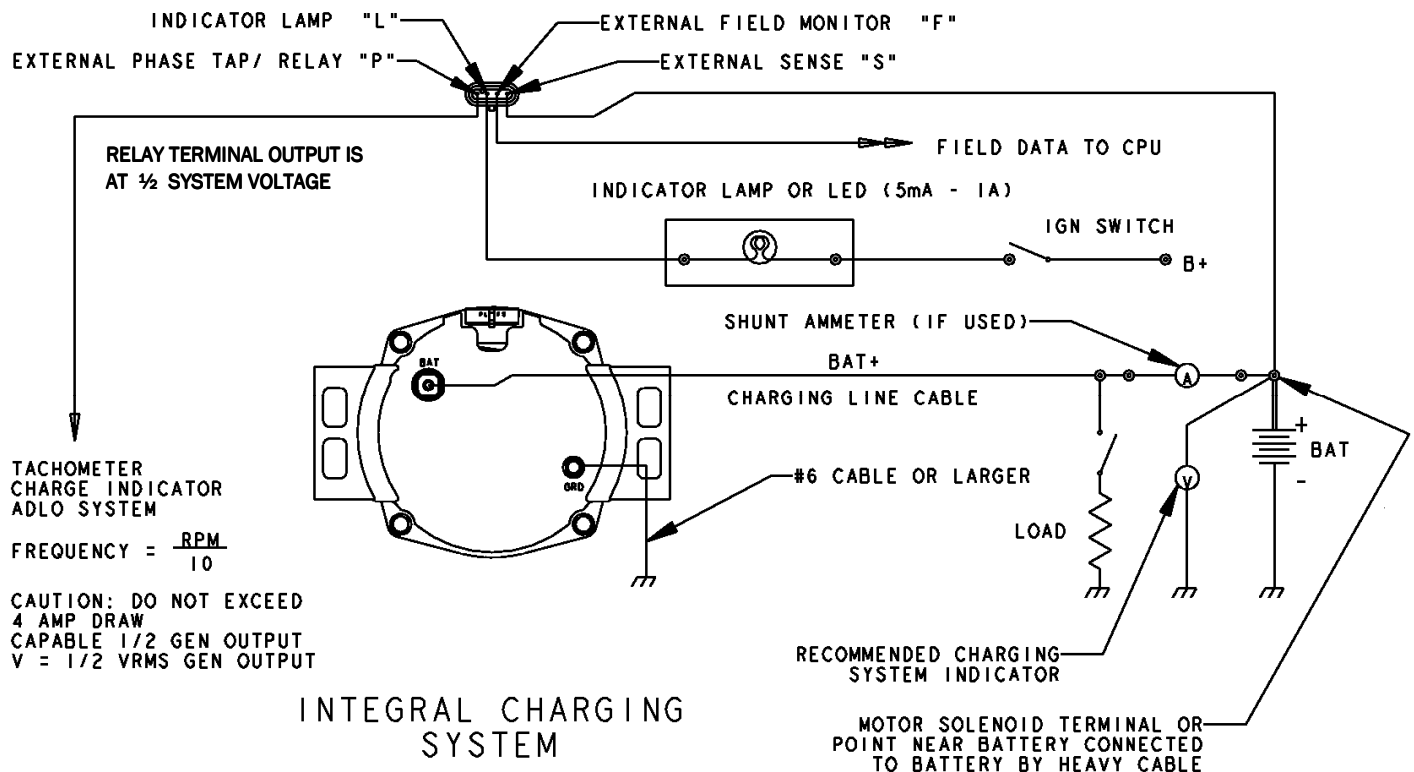

TERMINAL DESCRIPTIONS (P, L, F and S terminal connections are optional):

- “B+” Terminal - Output terminal connects to the positive (+) battery terminal.
 - “S” Remote Sense™ Terminal – Connect to system voltage at the battery or a common distribution point.
 - “P” Terminal – Relay / Phase terminal carries half system voltage and may be used for certain types of control relays, charge indicators, tachometers or similar devices. The current draw should not exceed four (4) amperes. Frequency = Alternator RPM/10.
 - “L” Terminal - The regulator Lamp or “L” terminal connects to the ignition switch through an indicator bulb or LED.
 - “F” Terminal - Connect to ECU or ECM Field data input terminal.
- Ground Screw** – Ground lead ensures alternator is grounded and is strongly recommended for optimum performance.

- ◆ If installing this alternator with **Remote Sense™** terminal in a vehicle that does not have a sense line, **connect a fused (5 Amp) insulated wire** from the Alternator Voltage Sense terminal to the positive (+) battery terminal or the common distribution point such as the starter solenoid battery (+) terminal. Connection of this terminal is best for optimum performance; however, the alternator will function without **Remote Sense™** connected.
- Use a **#16 gauge red insulated wire**, preferably with a 1/4" ID Convuluted Polyethylene Conduit. Also install a **standard inline fuse holder with a protective cap**. Use a low voltage automotive standard blade style fuse, 5 Amp.
- ◆ Only connect the Remote Sense™ terminal line to the Remote Sense™ terminal. **The “R” and “I” Terminals are not the Remote Sense™ Terminal!**

NOTICE - Only licensed Remy Inc. product and component parts should be used, and the use of other parts or modifications not approved by Remy Inc. will void all applicable warranties. The failure to carefully follow these Installation Instructions, set forth above, will void all applicable warranties. Delco Remy® is a registered trademark of General Motors Corporation, licensed to Remy Inc., Pendleton, IN 46064.