

26SI & 27SI HEAVY DUTY ALTERNATOR INSTALLATION INSTRUCTIONS

WARNING!!! ALWAYS USE PROPER EYE PROTECTION WHEN PERFORMING ANY MECHANICAL REPAIRS TO A VEHICLE – INCLUDING, BUT NOT LIMITED TO, ANY INSTALLATION AND OR REPAIRS TO THE DELCO REMY ALTERNATORS. FAILURE TO USE PROPER EYE PROTECTION CAN LEAD TO SERIOUS AND PERMANENT EYE DAMAGE.

Only perform the mechanical functions that you are properly qualified to perform. Mechanical repairs that are beyond your technical capabilities should be handled by a professional installation specialist.

DANGER!!! To avoid injury or damage, always disconnect the negative cable at battery before removing or replacing the alternator. The alternator output terminal is always live (“hot”). If the battery is not disconnected, a tool accidentally touching this terminal and ground can quickly get hot enough to cause skin burn or damage to the tool and surrounding parts.

FOLLOW ENGINE OR VEHICLE MANUFACTURER’S INSTRUCTIONS FOR REMOVING THE OLD ALTERNATOR FROM THE ENGINE AND INSTALLING THE NEW ALTERNATOR.

PULLEY INSTRUCTIONS: Use pulley from the old alternator if this alternator does not have a pulley or pulley supplied is different from the one on alternator being replaced. Hold the shaft by placing a hex-wrench in the hexagonal hole in the end of the shaft while removing or installing the pulley. Tighten the pulley nut to **100 Nm (75 lb ft)**. If there are any spacers when removing the pulley, make sure all spacers are replaced when installing the pulley on this alternator.

BELT TENSIONING INSTRUCTIONS FOR HINGE MOUNT: Improper belt tension can damage the alternator or cause the bearings to fail later. If the belt must be tightened manually, pry only against the drive end (DE) frame [1]. If that is not possible, use a wood block with one end positioned against the DE frame between the pry bar and alternator. Use a torque wrench to tighten the mounting bolts to specified torque. Follow engine or vehicle manufacturer’s specifications carefully for belt tension and mounting bolts torque. **DO NOT OVER TIGHTEN BELT!**

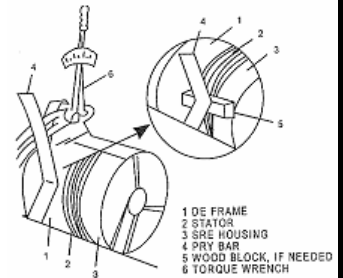

DESCRIPTION OF TERMINALS:

“BAT” OUTPUT Terminal - Connects to the Positive (+) Battery terminal and Charges the Battery. **NOTE:** If it is a positive ground (+) model, it connects to the Negative Battery (-) terminal.

“R” RELAY PIN Terminal - Carries half systems voltage and may be used for certain types of control relays, charge indicators, tachometers or similar devices. The current draw should not exceed four (4) amperes.

“I” INDICATOR LIGHT Terminal – It’s normally connected to an indicator lamp; maximum current draw is 1 ampere).

GROUND (-) Terminal Grounds the alternator. A Ground lead is strongly recommended for optimum performance.

INSTALLATION INSTRUCTIONS:

- ◆ Disconnect the negative (-) cable at the batteries.
- ◆ Identify and tag all leads when removing the old Alternator and install on the same terminals of the new 27SI Alternator.
- ◆ Insure all leads are hooked back up or contained where they can not ground.
- ◆ **Torque all fasteners as labeled on the illustration.**

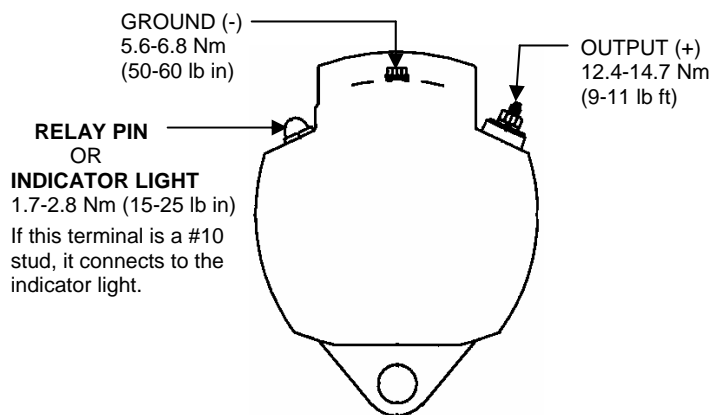

26SI ALTERNATOR

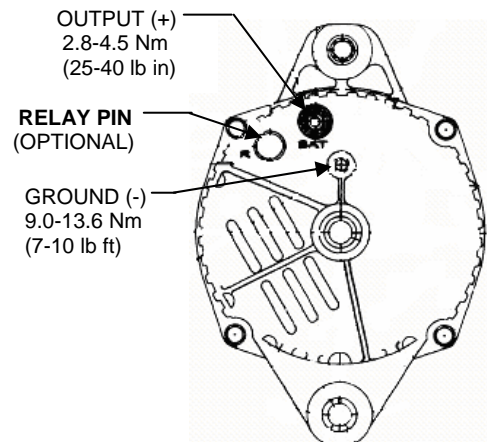

27SI ALTERNATOR

WARNING - Be aware that only licensed Remy Inc. product and component parts should be used and the use of other parts or modifications not approved by Remy Inc. will void any warranty concerning, but not limited to, product performance or reliability. The failure to carefully follow Installation Package guidelines set forth above will likewise void any and all warranty, **including the implied warranties of merchantability and fitness for a particular purpose.** Delco Remy® is a registered trademark of General Motors Corporation, licensed to Remy Inc., Anderson, IN 46013.