

## SOLENOID PACKAGE FOR PASSENGER CAR 5MT, 10MT, 20MT, AND 27MT STARTERS

**WARNING!!!** ALWAYS USE PROPER EYE PROTECTION WHEN PERFORMING ANY MECHANICAL REPAIRS TO A VEHICLE – INCLUDING, BUT NOT LIMITED TO, ANY INSTALLATION AND OR REPAIRS TO THE DELCO REMY STARTING MOTORS. FAILURE TO USE PROPER EYE PROTECTION CAN LEAD TO SERIOUS AND PERMANENT EYE DAMAGE.

Only perform the mechanical functions that you are properly qualified to perform. Mechanical repairs that are beyond your technical capabilities should be handled by a professional installation specialist.

**NOTICE!** FOLLOW ENGINE OR VEHICLE MANUFACTURER'S INSTRUCTIONS CAREFULLY WHEN REMOVING AND INSTALLING THE STARTERS.

**THE SOLENOID BATTERY TERMINAL IS METRIC. BE SURE TO USE THE METRIC NUT PROVIDED ON THIS TERMINAL.**

On some applications, not all of the parts in this package will be needed when installing the solenoid. The remaining parts should be discarded.

### REPLACING SOLENOID

1. Remove original solenoid and return spring.
2. Assemble the return spring over the plunger and install new solenoid on starter.
3. Determine type of solenoid-to-motor terminal connection by referring to illustrations in either **TYPE A, B or C**. Observe applicable instructions when attaching field coil connector strap to solenoid.

#### FOR TYPE A (See Figure 1)

Attach field coil connector strap to motor terminal of solenoid, using short screw supplied.

#### FOR TYPE B (See Figure 2)

- a. Assemble terminal connector (copper tube) on the motor terminal of the solenoid.
- b. Attach field coil connector strap to motor terminal of solenoid, using long screw supplied.

#### FOR TYPE C (See Figure 3)

Assemble original connector strap and two plain washers (1/32" and 1/16" thickness) on motor terminal of solenoid and attach, using lock washers and short screw supplied.

4. If the battery cable connector has a locating tang, bend or cut it away before reconnecting cable to the battery terminal of the replacement solenoid.
5. If the original solenoid had the "R" terminal connected, reconnect same wire to "R" terminal on replacement solenoid.

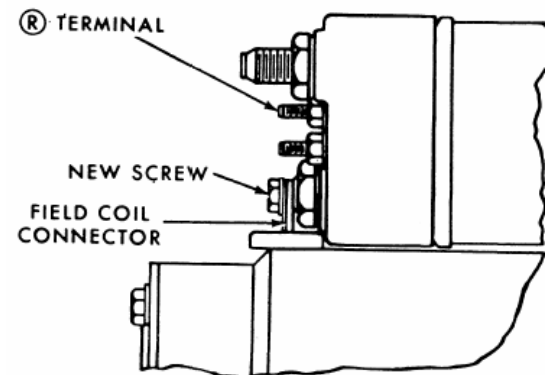

Figure 1

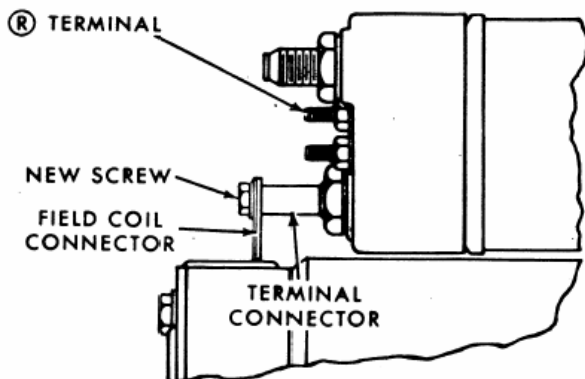

Figure 2

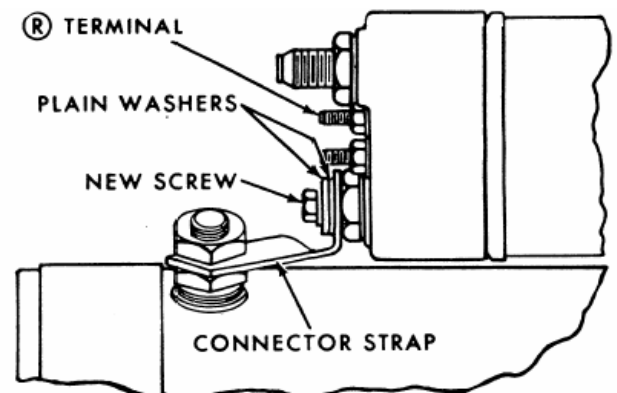

Figure 3

**WARNING -** Be aware that only licensed Remy Inc. product and component parts should be used and the use of other parts or modifications not approved by Remy Inc. will void any warranty concerning, but not limited to, product performance or reliability. The failure to carefully follow Installation Package guidelines set forth above will likewise void any and all warranty, including the implied warranties of merchantability and fitness for a particular purpose. Delco Remy® is a registered trademark of General Motors Corporation, licensed to Remy Inc., Anderson, IN 46013.